

D Ersatzteilliste Rasenmäher**Primo 550****550 H****550 R****550 HR****550 RS****550 HRM****Inhaltsverzeichnis**

Seite

2	Gehäuse
4	Hinterradachse
5	Hinterradachse R/RS/HR/SM
6	Vorderradachse
7	Messerantrieb
8	Holm 550/H/R/HR/RS/HRM
9	Bedienteile
13	Ersatzteile
13	Richtlinien für die Bestellung

GB Spare parts list Lawnmower**Table of contents**

Page

2	Housing
4	Rear wheel axle
5	Rear wheel axle R/RS/HR/SM
6	Front wheel axle
7	Blade drive
8	Handle 550/H/R/HR/RS/HRM
9	Operating parts
13	Spare parts
13	Directions for ordering

F Liste de pièces de rechange Tondeuse**Table des matières**

Page

2	Carter
4	Axe de roue arrière
5	Axe de roue arrière R/RS/HR/SM
6	Suspension de la roue avant
7	Entrainement couteau
8	Guidon 550/H/R/HR/RS/HRM
9	Eléments de fonction
13	Pièces de rechange
13	Directives pour les commandes

E Lista de piezas de recambio Cortacesped**Indice**

Página

2	Carter
4	Eje
5	Eje R/RS/HR/SM
6	Delantero eje
7	Accionamiento de cuchilla
8	Larguero 550/H/R/HR/RS/HRM
9	Partes de manejo
13	Piezas de recambio
13	Directivas de pedido

Primo 550 / H / R / HR / RS / HRM



Bild-Nr. Pos.-No. Pos.-No. Pos.-No.	Bestell-Nr. Order-No. No. de Cde. Ref.-Nr.	Modell Type Modélo Modelo	Menge Quantity Nombres Cantidad	Gehäuse	Housing	Carter	Carter
1	50 73 618		1	Rasenmähergehäuse Aufsatz	mower deck top	capôt carter principal	carter cortacesped
2	50 73 645		1	Schaufel	collector	collecteur	colector
3	53 00 640		1	Rahmen	frame	cadre	bastidor
4	59 00 772		1	Grasfangsack	grass catcher	sac à herbe	colector de hierba
5	59 00 774		1	Abdeckung	cover	couvercle	cubierta
6	53 00 634		1	Schutzklappe mit Griff	protection flap with handle	clapet protection avec poignée	tapa de protection con palanca
7	50 74 562		1	Griff	handle	poignée	palanca
8	00 18 258		2	Linsenschraube 5x18	screw	vis	tornillo
9	50 36 403		1	Achse	axle	axe	eje
10	00 73 299		1	Drehfeder 3x12	spring	ressort	resorte
11	50 73 670	550/H/R/HR	1	Aufsatzdeckel	top cover	capôt de couvercle	tapa
12	00 18 258		2	Linsenschraube 5x18	screw	vis	tornillo
13	50 42 818		2	Halteblech	support plate	tôle de support	chapa soporte
14	00 18 257		8	Linsenschraube 5x25	screw	vis	tornillo
15	00 18 346		1	Zylinderschraube M6x16	screw	vis	tornillo
16	00 30 125		1	Scheibe 6,4 DIN 9021	washer	rondelle	arandala
17	20 43 411		1	Befestigungswinkel	support angle	tirant	angulo
18	00 28 111		1	Sechskantmutter M6 DIN 980	nut	écrou	tuerca
19	00 71 213		1	Zugfeder 1x7x125	tension spring	ressort de traction	resorte de tension
20	50 73 670	RS	1	Abdeckung Batterie	battery cover	couverture batterie	cubierta bateria
21	00 84 572	RS	1	Batterie 12V	battery 12V	batterie 12V	bateria 12V
22	79 00 297	RS	1	Ladegerät	battery charger	charge batterie	cargadon
23	00 24 121	RS	4	Hutmutter M5	nut	écrou	tuerca
24	00 30 108	RS	4	Scheibe 5,3 125 B	washer	rondelle	arandela
25	00 18 336	RS	4	Zylinderschraube M5x16	screw	vis	tornillo

Primo 550 / H / R / HR / RS / HRM

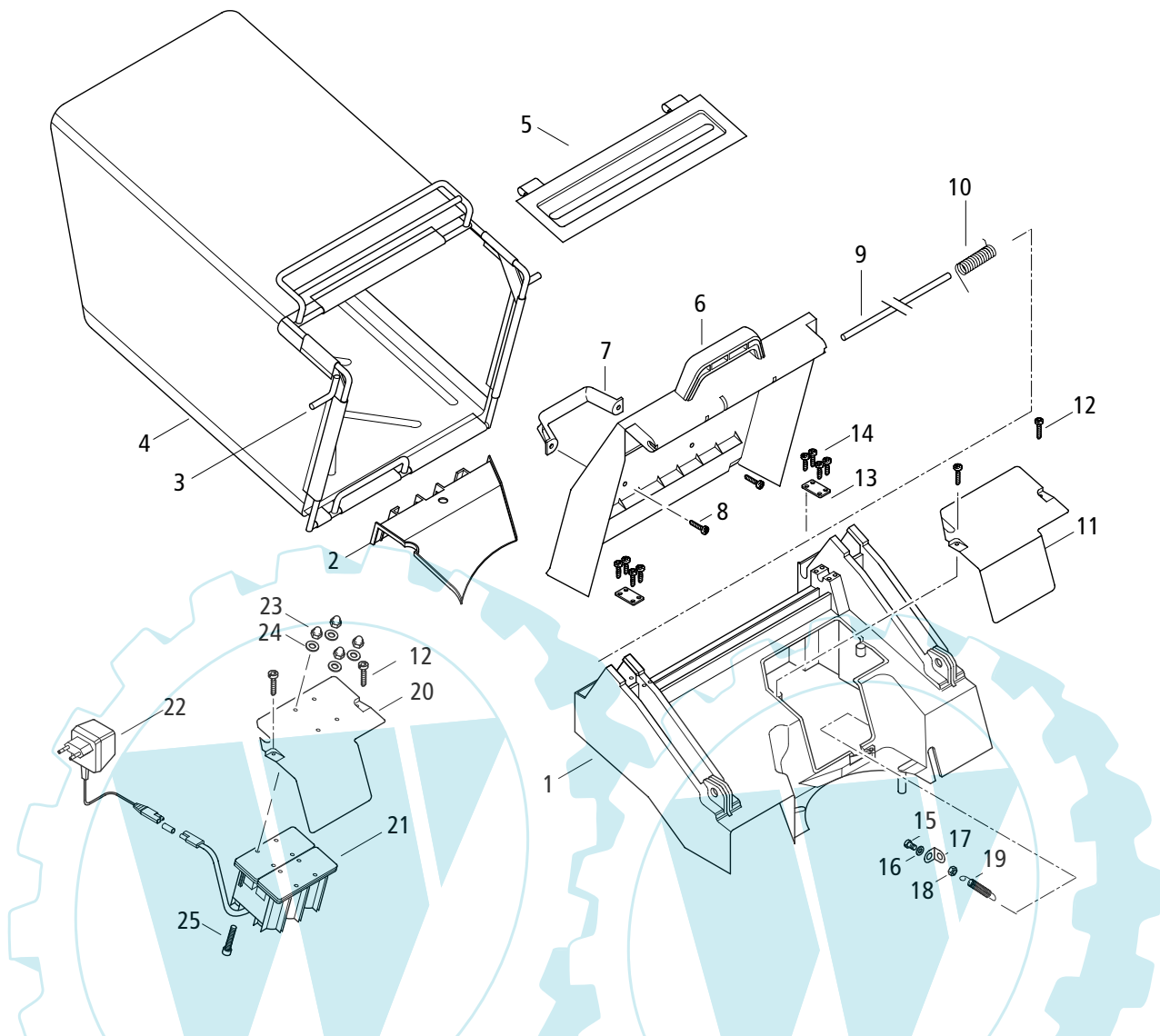

Bild-Nr. Pos.-No. Pos.-No.	Bestell-Nr. Order-No. No. de Cde. Ref.-Nr.	Modell Type Modélo Modelo	Menge Quantity Nombres Cantidad	Gehäuse	Housing	Carter	Carter
1	50 11 714		1	Rasenmähergehäuse	mower deck	carter principal	carter cortacesped
1	50 11 715	550/R/ HR/RS	1	Rasenmähergehäuse	mower deck	carter principal	carter cortacesped
2	00 18 276		8	Linsenschraube 505	screw	vis	tornillo
8	58 00 454		1	Bowdenzugbefestigung Vario	bowden cable fast.	fixation câble bowden	soporte cable
30	50 48 372		1	Schaumstoffdichtung	foam gasket	joint mousse nylon	junta
31	00 18 402		1	Sechskantschraube 10-2418	screw	vis	tornillo
32	00 30 125		1	Scheibe 6,4 DIN 9021	washer	rondelle	arandela
35	00 18 183		1	Sechskantschraube M6x16	screw	vis	tornillo
36	00 30 125		1	Scheibe 6,4 DIN 9021	washer	rondelle	arandela
37	00 71 227		1	Zugfeder 2,5x14,5x165	spring	ressort	resorte
38	00 55 244		2	Sicherungsscheibe 8 DIN 581	washer	arretage	disco
39	50 36 362		1	Verbindungsstange	connecting rod	tige de liaison	
43	00 18 282		2	Linsenschraube 5x45	screw	vis	tornillo
44	00 18 185		2	Sechskantschraube M6x20	screw	vis	tornillo
45	50 42 860		1	Lasche	flap	collier	cubre junta
46	00 33 398		2	Distanzrohr	spacer tube	tube distance	tobu distanciador
50	00 12 184	R	1	Sechskantschraube	screw	vis	tornillo
51	00 72 145	R	1	Scheibe	washer	rondelle	arandela
52	00 28 116	R	1	Sechskantmutter	nut	écrou	tuerca
53	53 00678	R	1	Spannhebel	tension lever	levier tension	palanca tensora
54	00 33 245 25	R	1	Distanzring	spacer	entretoise	pieza
55	53 00 585	R	1	Spannrolle	tension pulley	boulie de tension	distanciador
56	00 55 102	R	1	Sicherungsring	circlip	circlipc	antilo de seguridad
57	00 57 206	R	1	Keilriemen 8x5x775 Li.	v-belt	courroie	correa
60	58 00 452	R	1	Lagerbügel komplett	bracket compl.	étrier	soporte compl.
61	00 12 279		1	Sechskantschraube M8x60 DIN 901	screw	vis	tornillo
62	00 72 176		1	Scheibe 8,2x20x1 DIN 2093	washer	rondelle	arandela
63	00 33 392		1	Distanzrohr 12x1,8x26,2	spacer tube	douille	tubo espaciador
64	00 31 617		1	Anlaufscheibe 8,4x20x1,5	washer	rondelle	arandela
65	00 28 116		1	Sechskantmutter M8	nut	écrou	tuerca
66	00 71 235		1	Zugfeder 1,6x10x55	tension spring	ressort	resorte tension
67	00 57 221		1	Keilriemen x10-547 LD	v-belt	courroie	correa
68	00 57 220		1	Keilriemen x10-422 LD	v-belt	courroie	correa
69	58 00 458		1	Klebeschilder-Set	sticker-set	autocollants	juego de

Primo 550 / H / R / HR / RS / HRM

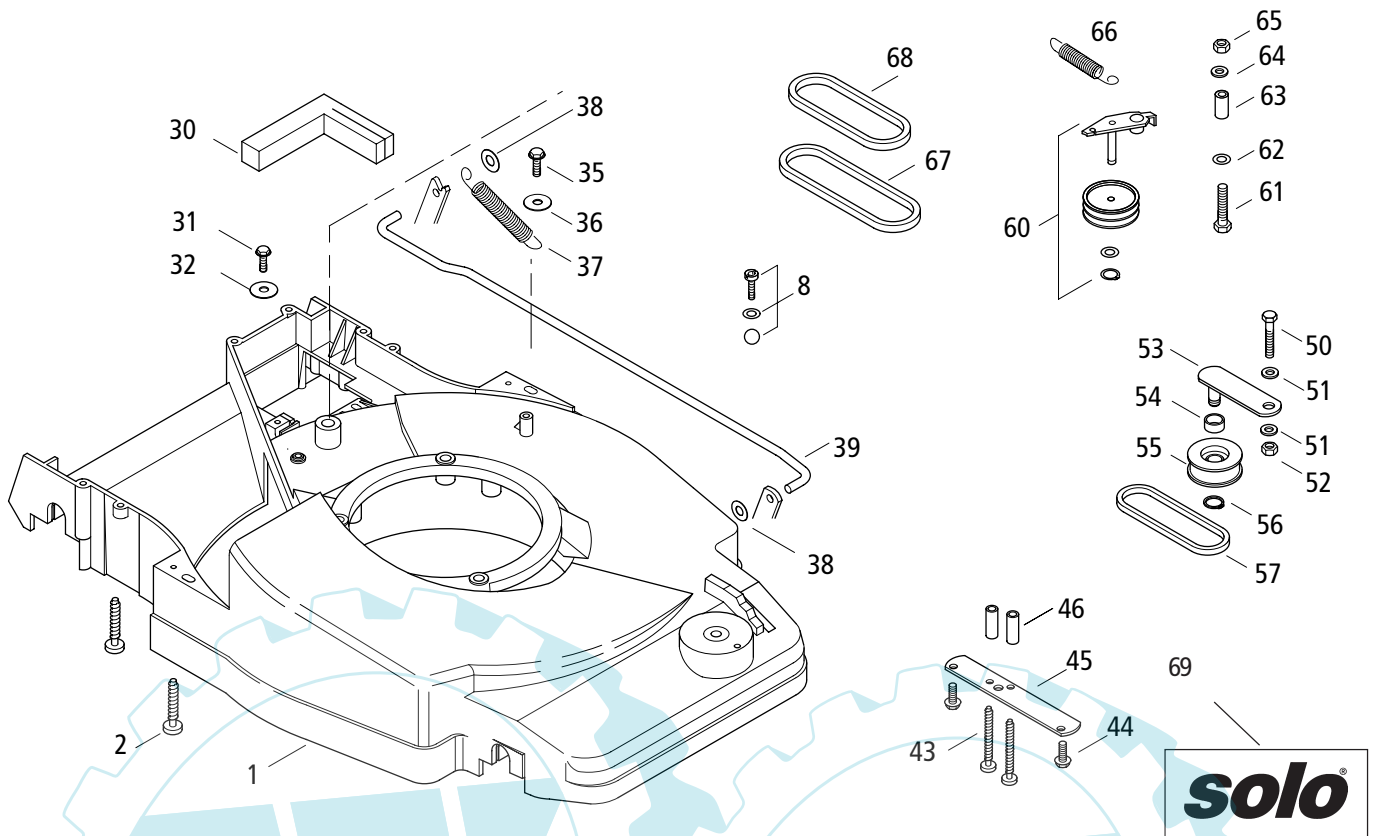

Bild-Nr. Pos.-No. Pos.-No. Pos.-No.	Bestell-Nr. Order-No. No. de Cde. Ref.-Nr.	Modell Type Modélo Modelo	Menge Quantity Nombres Cantidad	Hinterradachse	Rear wheel axle	Axe de roue arrière	Eje
1	50 74 102		2	Radkappe Ø 135 mm	wheel cover	chapeau de roue	tapa de rueda
2	00 18 193		4	Sechskantschraube M5x12	screw	vis	tornillo
3	00 31 540		4	Druckscheibe 5,5x27x1	pressure washer	rondelle de pression	arandela de presion
5	53 00 632		2	Rad Ø 200 mm	wheel	roue	rueda
7	00 31 210		2	Scheibe 12x18x1,2 DIN 988	washer	rondelle	arandela
8	00 72 155		2	Tellerfeder 12,5x25x0,7	spring	ressort plat	resorte de disco
10	53 00 625		1	Hinterradlagerung	rear wheel bearing	support roue arriere	apoyo
11	50 74 176		2	Lagerschale 10,2	bearing cup	coussinet superieur	cojinete, parte sup.
12	50 74 175		2	Lagerschale 10,2	bearing cup	coussinet inferieur	cojinete bajo
13	50 42 824		2	Achslagerblech	axle support plate	couvercie d'axe	chapa soporte eje
14	00 18 185		2	Sechskantschraube M6x20	screw	vis	tornillo

Primo 550 / H / R / HR / RS / HRM

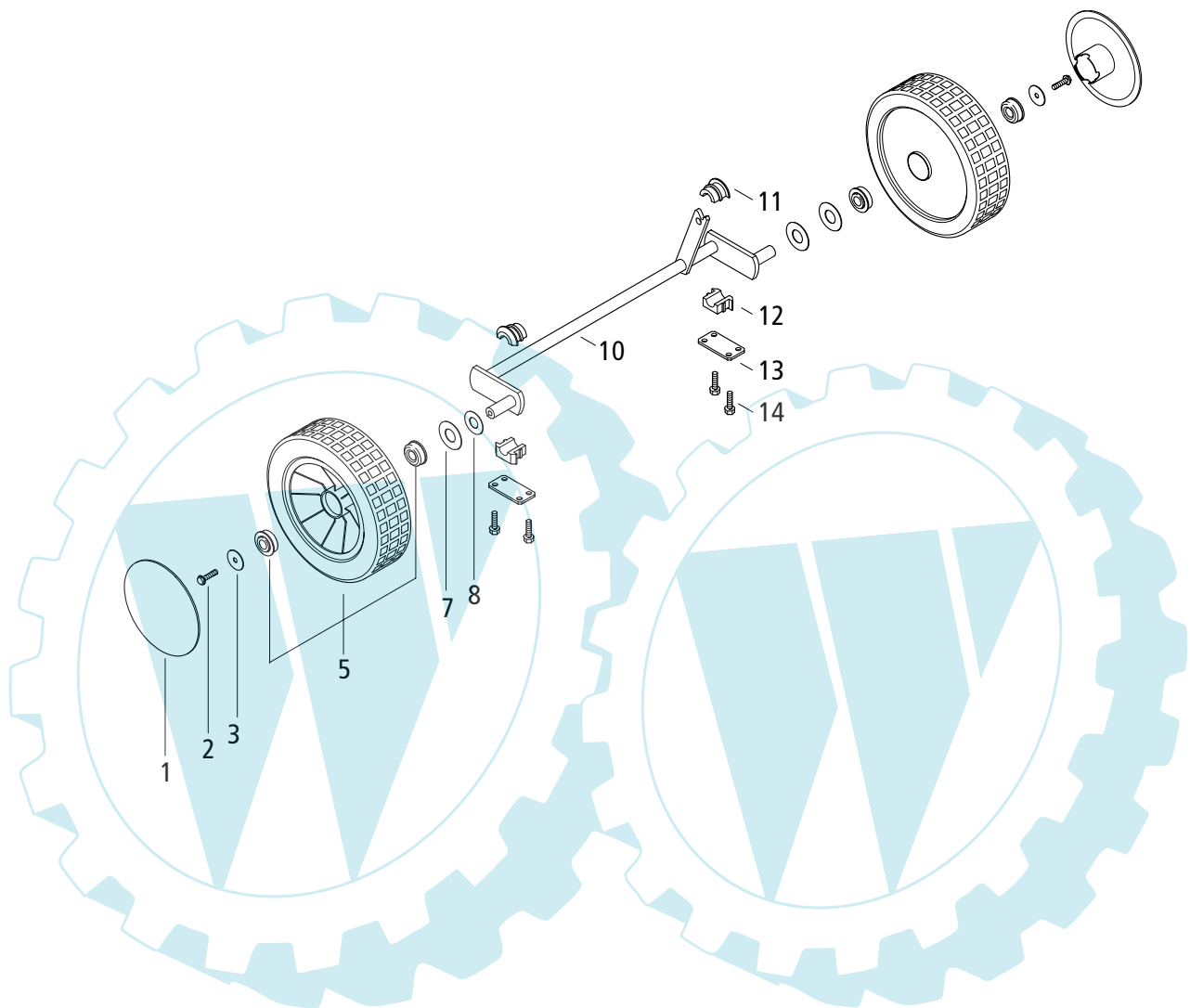

Bild-Nr. Pos.-No. Pos.-No.	Bestell-Nr. Order-No. No. de Cde. Ref.-Nr.	Modell Type Modélo Modelo	Menge Quantity Nombres Cantidad	Hinterradachse R / RS / HR	Rear wheel axle	Axe de roue arrière	Eje
1	50 74 157		2	Radkappe	wheel cover	chapeau de roue	tapa de rueda
2	00 18 193		2	Sechskantschraube M5x12	screw	vis	tornillo
3	00 31 540		2	Druckscheibe 5,5x27x1	pressure washer	rondelle de pression	arandela
5	53 00 674		2	Rad, Ø 200 mm	wheel	roue	rueda
9	00 31 210		2	Scheibe 12x18x1,2 DIN 988	washer	rondelle	arandela
10	00 72 155		2	Tellerfeder 12,5x25x0,7	spring washer	ressort plat	resorte
11	00 31 552		2	Anlaufscheibe 12,2x35x0,5	friction washer	rondelle	arandela
12	50 73 631		2	Abdeckung	cover	couvercle	cubierta
15	00 55 134		2	Sicherungsscheibe 9 DIN 6799	circlip	circlip	arandela
16	00 31 618		2	Anlaufscheibe 12,2x30x1	friction washer	rondelle	arandela
17	00 61 336		2	Filzring 22,5x27x3,5	felt ring	bague feutre roue	anillo de fieltro
18	50 38 438		1	Zahnrad, 14 Zähne, Mod. 2,5	toothed wheel with	dentée avec axe libre	rueda dentada
19	50 38 437		1	Zahnrad, 14 Zähne, Mod. 2,5	toothed wheel with	dentée avec axe libre	rueda dentada
20	00 40 196		2	Stift	pin	goupille	perno
21	50 45 702		2	Topf	box	pot	pote
22	50 74 124		2	Lagerschale, 18,2 Oberteil	bearing cup, upper part	demi coque arbre	casaca
23	50 74 125		2	Lagerschale, 18,2 Unterteil	bearing cup, lower part	demi coque arbre	casaca
24	50 42 824		4	Achslagerblech	axle support plate	couverde d'axe	chapa soporte eje
25	00 18 185		4	Sechskantschraube M6x20	screw	vis	tornillo
26	00 53 213		4	Gleitlager 12x14x15	slide bearing	coussinet	cojinete de
28	53 00 668		1	Hinterradlagerung	rear wheel support	support roue arrière	soporte rueda
29	00 28 107		1	Sechskantmutter M8 DIN 980	nut	ecrou	tuerca
30	00 17 103		1	Sechskantschr. M8x20 DIN 933	screw	vis	tornillo
31	53 00 669		1	Hinterradlagerung, links	rear wheel support	support roue arrière roue	soporte rueda
32	00 31 537		2	Anlaufscheibe 12,2x26x1	friction washer	rondelle	arandela
33	30 00 227		1	Getriebe	gear	engrenage	engranaje
35	53 00 683		1	Hinterradachse, kompl.	rear wheel axle, compl.	axe de roue arrière,	eje, compl.
37	50 74 130	550/R	1	Keilriemenscheibe	v-belt pulley	poulie à courroie	polea para correa
37	50 74 131	RS/HR/HR-	1	Keilriemenscheibe	v-belt pulley	poulie à courroie	polea para correa
38	00 72 143	M	1	Sicherungsscheibe	tension washer	rondelle de tension	arandela
39	00 72 102		1	Sicherungsscheibe	tension washer	rondelle de tension	arandela
40	00 18 344		1	Zylinderschraube M6x12	screw	vis	tornillo

Primo 550 / H / R / HR / RS / HRM

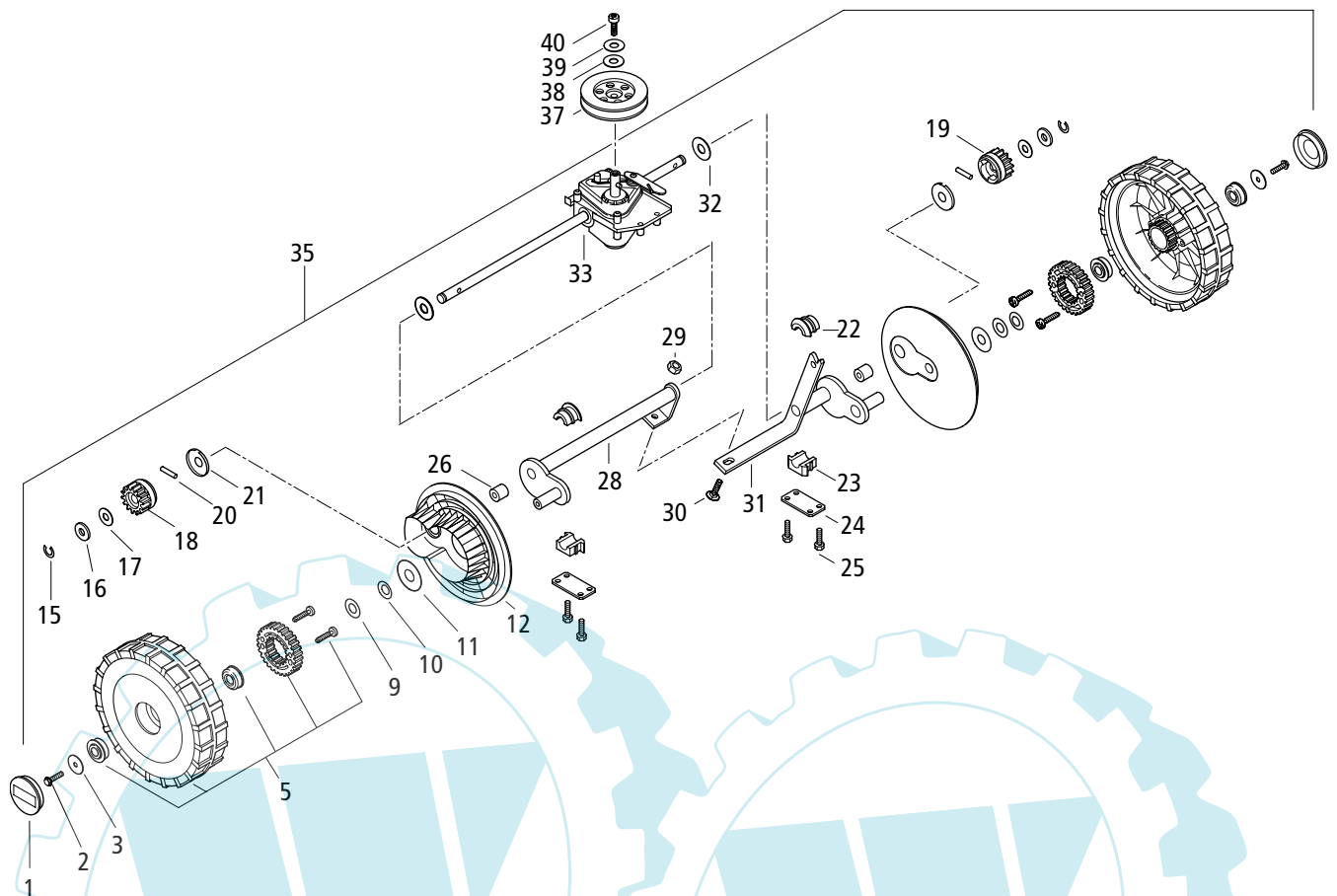

Bild-Nr. Pos.-No. Pos.-No.	Bestell-Nr. Order-No. No. de Cde. Ref.-Nr.	Modell Type Modélo Modelo	Menge Quantity Nombres Cantidad	Vorderradachse	Front wheel axle	Suspension de la roue avant	Delantero eje
1	50 74 104		2	Radkappe, Ø 115 mm, rot	wheel cover, red	chapeau de roue, rouge	tapa de rueda,
2	00 18 193		4	Sechskantschraube M5x12	screw	vis	rojojillo
3	00 31 540		4	Druckscheibe 5,5x27x1	pressure washer	rondelle de pression	arandela
5	53 00 613		2	Rad, Ø 180 mm	wheel	roue	rueda
6	00 31 210		2	Scheibe 12x18x1,2 DIN 988	washer	rondelle	arandela
7	00 72 155		2	Tellerfeder 12,5x25x0,7 DIN 2093	spring	ressort plat	resorte
10	50 74 176		2	Lagerschale 14,1, Oberteil	bearing cup, upper	coussinet superieur	cojinete
11	50 74 175		4	Lagerschale 14,1, Unterteil	bearing cup, lower	coussinet inwieur	cojinete
12	50 42 824		2	Achslagerblech	axle support plate	couverde d'axe	chapa soporte eje
13	00 18 185		4	Sechskantschraube M6x20	screw	vis	tornillo
15	53 00 624		1	Vorderradlagerung	front wheel support	support roue devant	soporte rueda
16	50 43 356		1	Führungsblech	guide plate	tôle guidage	chapa guia
17	00 18 185		4	Sechskantschraube M6x20	screw	vis	tornillo
18	00 11 310		1	Zylinderschraube M6x16	screw	vis	tornillo
20	00 20 122		1	Sechskantmutter M6 EN 27040	lock nut	âcrou	tuerca
21	00 30 100		1	Scheibe 6,4 DIN 125 B	washer	rondelle	arandela
22	58 00 276		1	Gewindespindel T14x2	threaded spindle	broche filete	husillo roscado
23	00 31 497		1	Anlaufscheibe 10,2x30x1,5	washer	rondelle	arandela
24	50 42 830		1	Lasche	flap	collier	cubrejunta
25	00 10 583		1	Zylinderschraube M6x30 DIN	screw	vis	tornillo
26	58 00 455		1	Verstellknopfbefestigung	adjustment knob	fixation bouton	d'ajustage soporte

Primo 550 / H / R / HR / RS / HRM

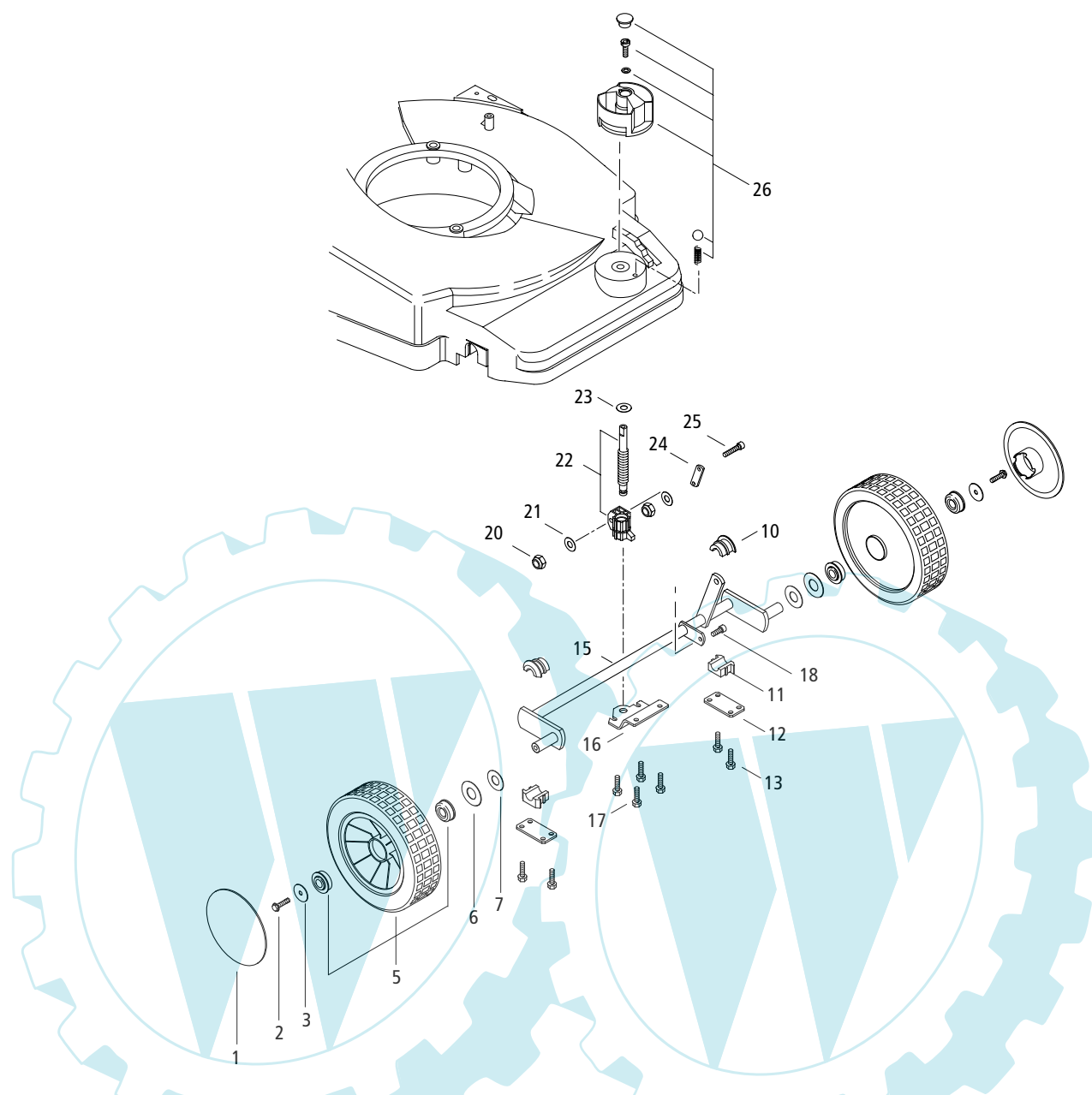

Bild-Nr. Pos.-No. Pos.-No.	Bestell-Nr. Order-No. No. de Cde. Ref.-Nr.	Modell Type Modelo Modelo	Menge Quantity Nombres Cantidad	Messerantrieb	Blade drive	Entrainement couteau	Accionamiento de cuchilla
1	00 10 544		1	Zylinderschraube 3/8" 24UNFAO	screw	vis	tornillo
2	00 34 177		1	Federring 10 DIN 7980	spring ring	rondelle belville	anillo
3	50 31 223		1	Druckstück	thrust washer	pike de pression	arandela
4	00 31 293		2	Druckscheibe	washer	rondelle	arandela
5	00 31 295		2	Reibscheibe	washer	rondelle	arandela
6	00 12 375		2	Sechskantschraube 6,302 DIN 7976	screw	vis	tornillo
10	50 43 995		1	Propellermesser 480x70x3	cutting blade	lame de coupe	cuchilla
11	00 72 158		1	Tellerfeder 32,5x56x3	spring	rondelle plat	resorte
12	00 75 123		2	Scheibenfeder 46,5 DIN 6888	disc spring	clavette demi-lune	resorte
13	53 005 31		1	Rohrnappe 22,25x36x61,5	tube hub	moyeu	cubo
15	50 74 910	550/R	1	Keilriemenscheibe	V-belt pulley	poulie à courroie	polea para correa
15	50 74 911	RS/HR	1	Keilriemenscheibe	V-belt pulley	poulie à courroie	polea para correa
16	50 73 577		1	Gebälserad	fan wheel	turbine	turbina
17	00 18 305		3	Sechskantschraube M8x16	screw	vis	tornillo
18	50 42 828		1	Abdeckblech	cover plate	tôle de couverture	chapa cubierta
19	00 18 283	550/R/RS	3	Sechskantschraube 3/8"x2"	screw	vis	tomillo
20	00 18 376	550/R/RS	2	Linsenschraube 4 x30 mm	screw	vis	tornillo
21	50 73 673	550/R/RS	1	Motorhaube	engine cover	capôt moteur	cubierta de motor
22	00 69 218	550/R/RS	1	Selbstklebeschild Motorhaube	Decal	Autocollant Solo	Adhesivo
23	50 43 961		1	Mulchmesser	mulching blade	couteau mulching	cuchilla
24	20 00 401	550/R	1	B & S Motor 190 ccm	B & S engine	moteur B & S	motor B & S
24	20 00 425	RS	1	B & S Motor 190 ccm	B & S engine	moteur B & S	motor B & S
24	20 00 497	550/H/HR	1	HONDA Motor GCV, 160 ccm	HONDA engine	moteur HONDA	motor HONDA

Primo 550 / H / R / HR / RS / HRM

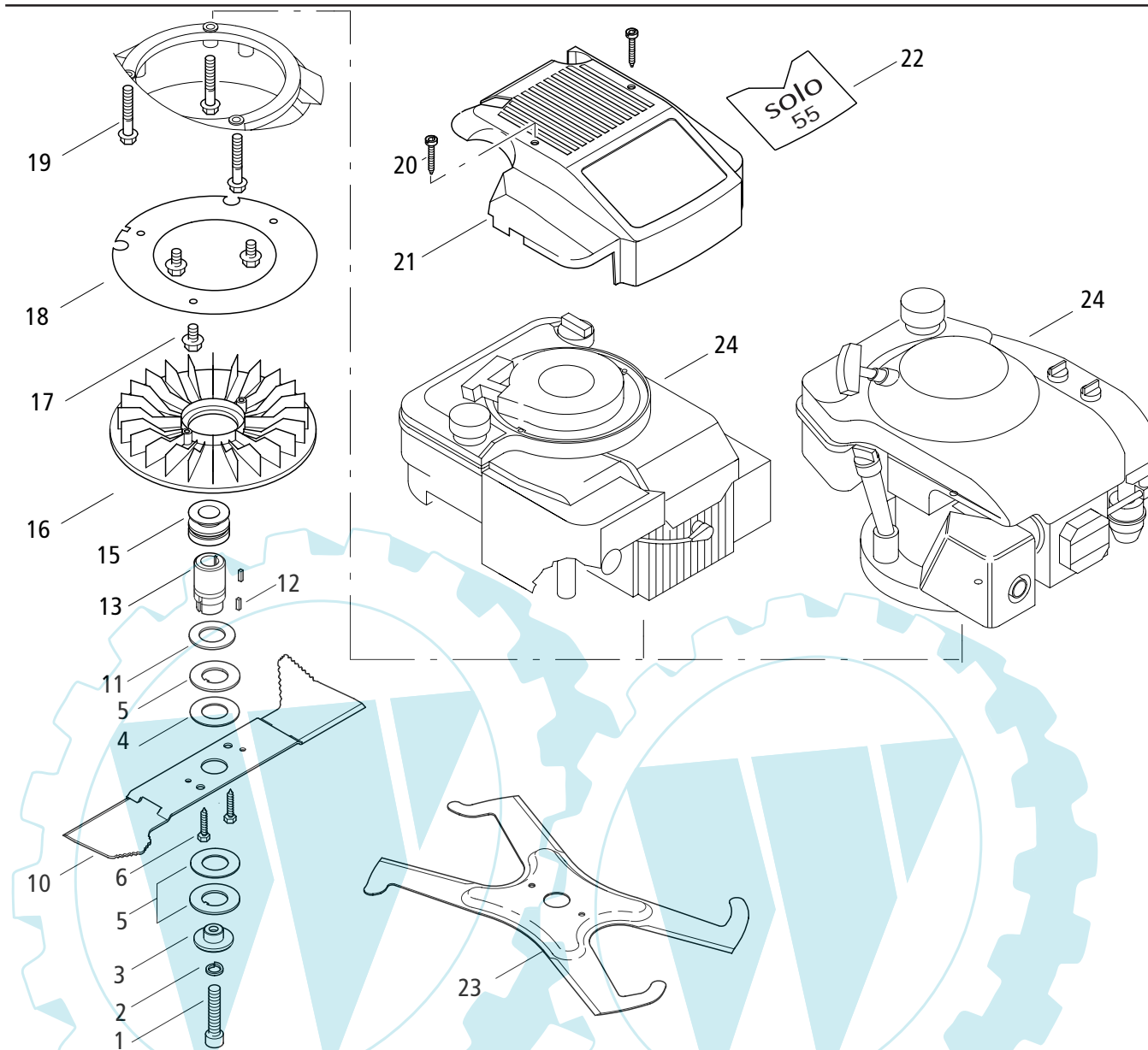

Bild-Nr. Pos.-No. Pos.-No.	Bestell-Nr. Order-No. No. de Cde. Ref.-Nr.	Modell Type Modélo Modelo	Menge Quantity Nombres Cantidad	Holm 550 / H / R / HR / RS / HRM	Handle	Guidon	Larguero
1	50 35 965		1	Holm- Oberteil	handle bar	guidon superieur	larguero
2	53 00 639		2	Holm- Unterteil	lower handle bar	longeron	larguero
3	00 17 110		2	Flachrundschaube M8x45	flat screw	vis	tornillo
4	00 17 113		2	Flachrundschaube M8x30	flat screw	vis	tornillo
5	00 94 293		4	Sterngriff M8	handle	étrier	mango
6	00 30 164		2	1 Scheibe 8,4x25x2	washer	rondelle	arandela
7	50 74 860		2	Klemmstück rechts	clip	collier	grapa
8	50 74 861		2	Klemmstück links	clip	collier	grapa
9	50 74 976		2	Lagerbolzen 12x23,5	bolt	goujon	pasador
10	50 74 100		1	Bowdenzughalter	bowden cable clamp	collier de serrage	soporte cable wden
11	50 74 246		2	Schutzkappe	protection cap	capuchon de protect.	caperuza protect.

Primo 550 / H / R / HR / RS / HRM

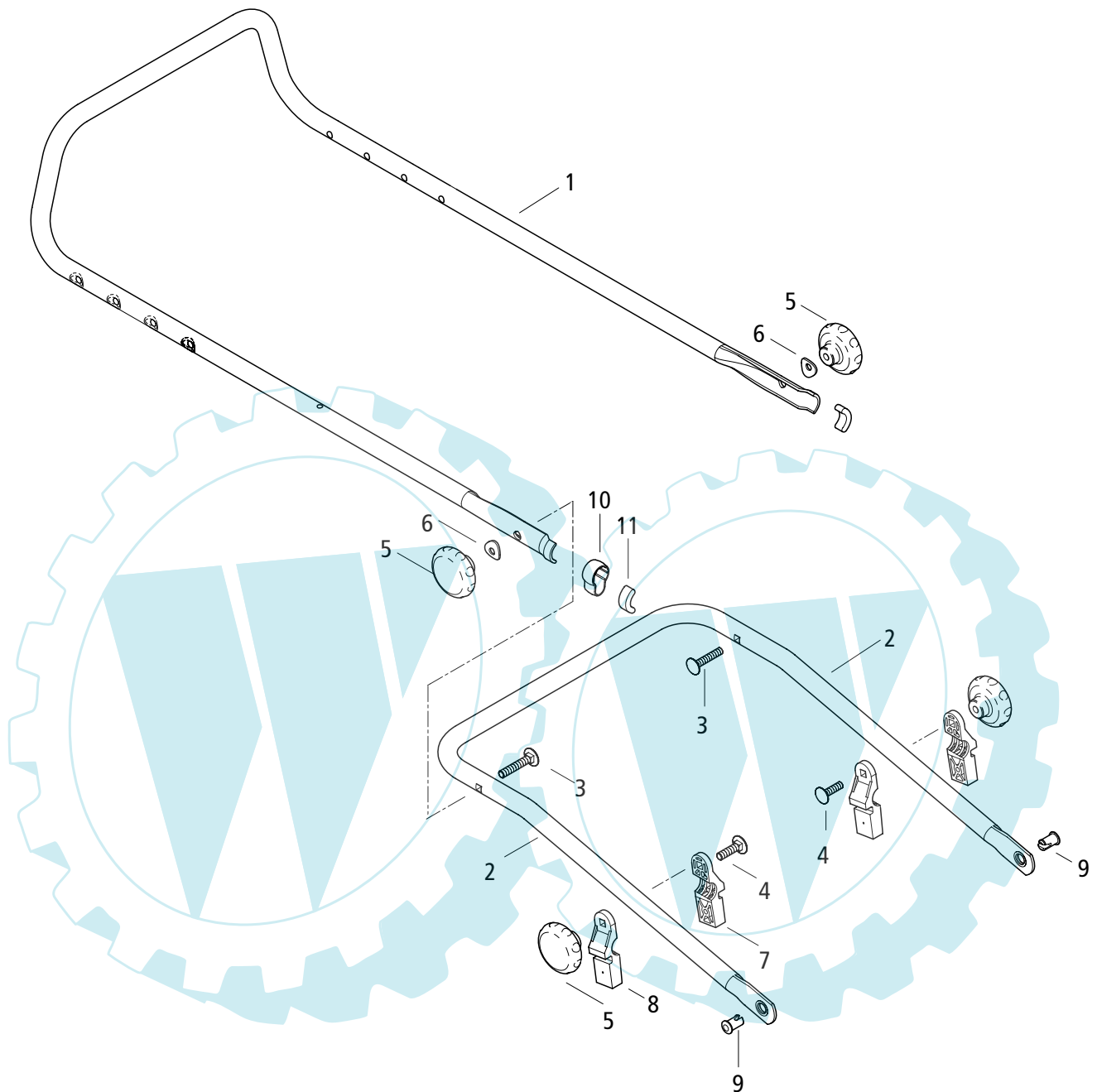

Bild-Nr. Pos.-No. Pos.-No.	Bestell-Nr. Order-No. No. de Cde. Ref.-Nr.	Modell Type Modelo	Menge Quantity Nombres Cantidad	Bedienteile 550 / R / HR / RS	Operating parts	Éléments de fonction	Partes de manejo
1	00 18 358		5	PT-Schraube-4x35 kt	screw	vis	tornillo
2	50 74 110		4	Halbschelle	clamp	collier	ambrazadera
3	50 74 958		2	Schaltgehäuse Außen	switch housing	boîtier commande	carter
4	00 40 197		2	Zylinderstift 6m6x28 DIN 7	pin	goujon	perno
5	50 74 127		1	Klemmstück	clamping piece	serre-joint	abrazadera
6	50 74 959		2	Schaltgehäuse Innen	switch housing	boîtier commande	carter
7	00 55 104		2	Sicherungsscheibe	circlip	rondelle	seguro
8	58 00 491		2	Bügel-Aufnahme	support	support	soporte
9	50 74 126		1	Schalthebel	switch lever	levier de commande	palanca
10	50 74 122		1	Schalthebel 2	switch lever	levier de commande	palanca
11	50 36 406		1	Verbindungsstange	connecting rod	tige de connection	barra de conexion
12	38 00 351		1	Bowdenzug Bremse	bowden cable	câble bowden	cable bowden
13	00 44 286		2	Abdeckklammer	clamp	collier	ambrazadera
14	50 35 111		1	Schalthebel Motorbremse	switch loop	étrier	estribo
15	50 74 440		2	Stopfen	plastic plug	bouchon en plastique	tapon plastico
17	50 74 956		1	Gehäuse Außen	switch housing	carter commande	carter
18	00 20 122		1	Sechskantm. selbsts. DIN 935-gelb	hex. nut	écrou	tuerca
19	50 74 950		1	Gashebel	lever	levier	palanca
20	58 00 478		1	Schaltgehäuse Innen, bedruckt Choke	switch housing	carter commande	carter
21	00 12 171		1	Sechskantschraube M6x30 DIN 931	screw	vis	tornillo
22	00 72 111		1	Scheibe 6,2x1 2x0,6-DIN 2093 TE	washer	rondelle	arandela
23	38 00 353	550	1	Bowdenzug- Gas	bowden cable	câble bowden	cable bowden
23	38 00 358	R / RS	1	Bowdenzug- Gas	bowden cable	câble bowden	cable bowden
23	38 00 355	HR / RA	1	Bowdenzug- Gas	bowden cable	câble bowden	cable bowden
24	50 31 980		1	Spezierschraube	screw	vis	tornillo
25	00 20 116		1	Sechskantmutter M6 DIN 439B gelb	hex. nut	écrou	tuerca
26	00 24 110		1	Hutmutter M6 DIN 1587	box nut	écrou à calotte	tuerca
28	00 18 376		2	PT-Schraube-4x30 kt	screw	vis	tornillo

Primo 550 / H / R / HR / RS / HRM

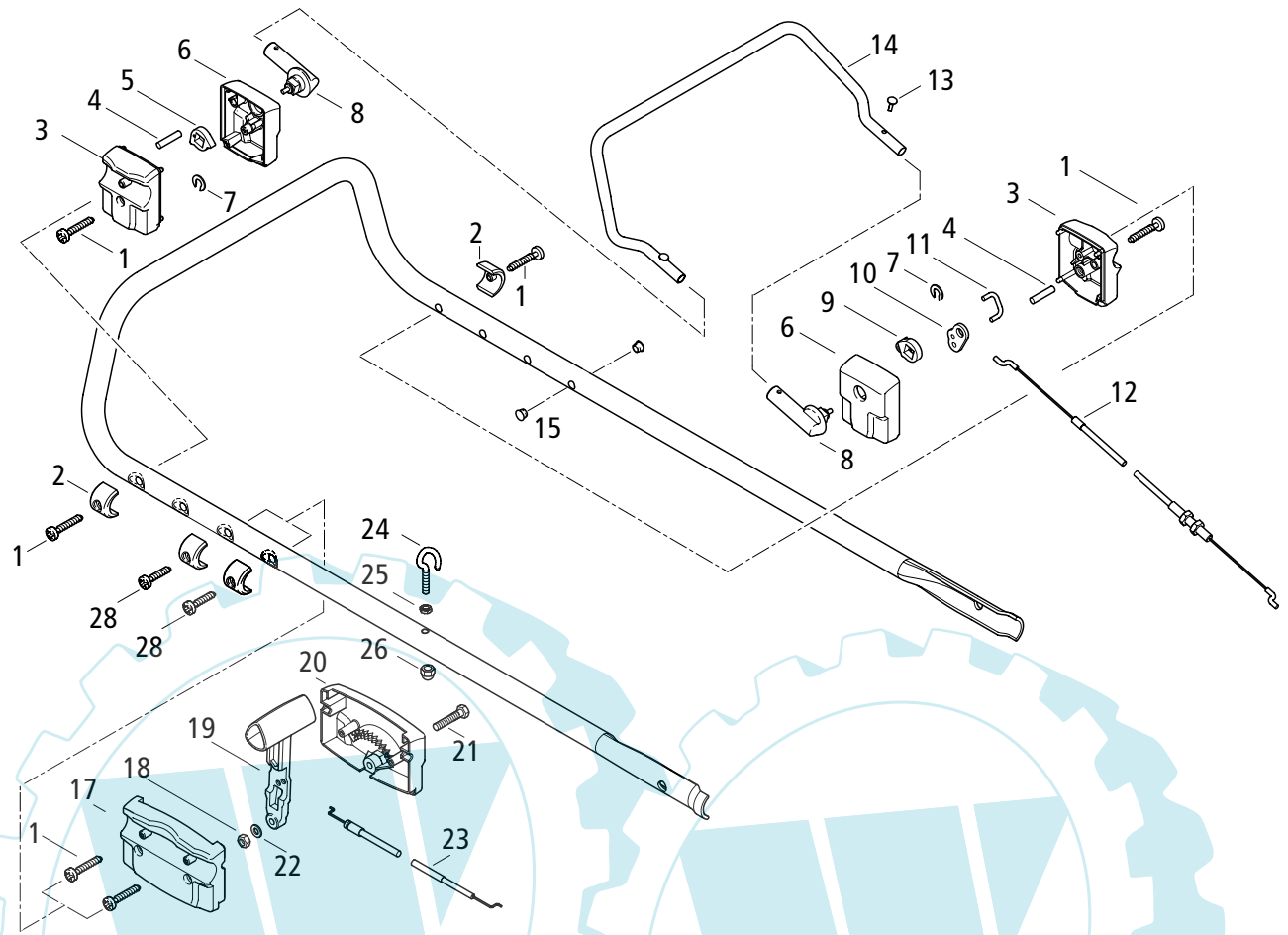

Bild-Nr. Pos.-No. Pos.-No.	Bestell-Nr. Order-No. No. de Cde. Ref.-Nr.	Modell Type Modelo Modelo	Menge Quantity Nombres Cantidad	Bedienteile R / HR / RS	Operating parts	Eléments de function	Partes de manejo
1	00 18 358		4	PT-Schraube-4x35 kt	screw	vis	tornillo
2	50 74 110		2	Halbschelle	clamp	collier	abrazadera
3	50 74 958		2	Schaltgehäuse Außen	switch housing	boîtier commande	carter
4	00 40 197		1	Zylinderstift 6m6x28 DIN 7	pin	goujon	perno
5	50 74 127		1	Klemmstück	clamping piece	serre-joint	abrazadera
6	50 74 959		2	Schaltgehäuse Innen	switch housing	boîtier commande	carter
7	00 55 104		2	Sicherungsscheibe	circlip	rondelle	seguro
8	58 00 491		2	Bügel-Aufnahme	support	support	soporte
9	50 16 100		1	Schaltnocken	switch lever	levier de commande	palanca
10	58 00 487		1	Schalthebel	switch lever	levier de commande	palanca
11	38 00 362		1	Bowdenzug Fahrtrieb	bowden cable	câble bowden	cable bowden
12	50 74 204		2	Endhülse	sleeve	doille	casquillo
13	00 64 427		1	Wellenschlauch d 12 mm	hose	gaine	tubo
15	00 44 286		2	Abdeckklammer	clamp	collier	abrazadera
16	50 35 112		1	Schaltbügel, Fahrtrieb	switch lop	étrier de commande	estribo

Primo 550 / H / R / HR / RS / HRM

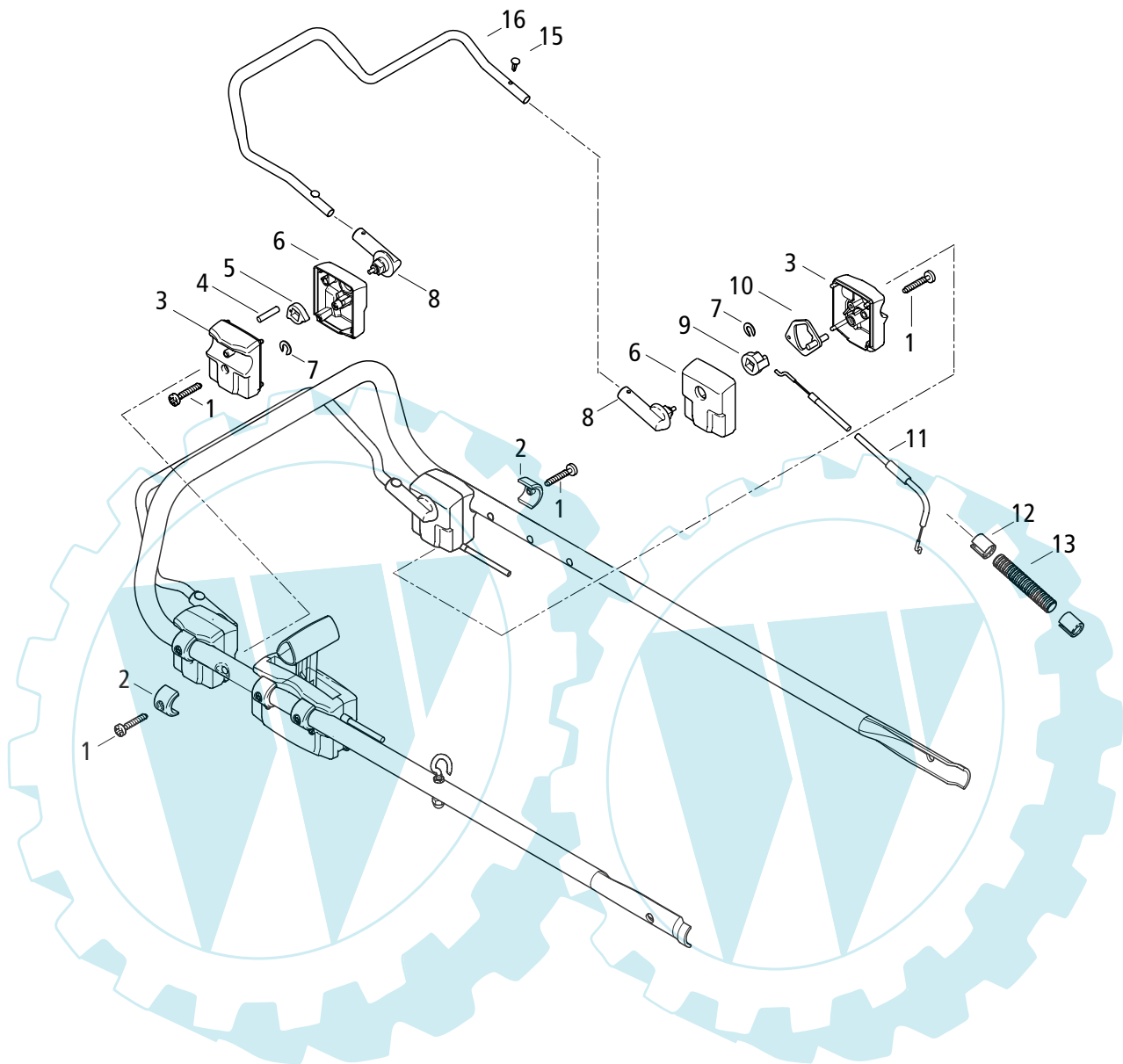

Bild-Nr. Pos.-No. Pos.-No.	Bestell-Nr. Order-No. No. de Cde. Ref.-Nr.	Modell Type Modélo Modelo	Menge Quantity Nombres Cantidad	Bedienteile HR / RS / SM	Operating parts	Eléments de function	Partes de manejo
1	50 74 110		2	Halbschelle	clamp	collier	abrazadera
2	00 18 358		4	PT-Schraube-4x35 kt	screw	vis	tornillo
3	58 00 479		1	Schaltgehäuse Innen, bedruckt	switch housing	boîtier commande	carter
4	58 00 488		1	Hebel mit Buchse	lever	levier	palanca
5	50 74 956		1	Gehäuse Außen	switch housing	boîtier commande	carter
7	00 28 119		1	Sechskantmutter M6 DIN 980	hex. nut	écrou	tuerca
8	00 72 111		2	Scheibe 6,2x12x0,6-DIN 2093 TE	washer	rondelle	arandella
9	00 30 125		1	Scheibe 6,4 DIN 9021 ST ZN Gelb	washer	rondelle	arandella
10	38 00 360		1	Bowdenzug Vario	bowden cable	câble bowden	cable bowden
11	00 12 125		1	Sechskantschr. M6x35 DIN 931-8.8	screw	vis	tornillo

Primo 550 / H / R / HR / RS / HRM

Bild-Nr. Pos.-No. Pos.-No.	Bestell-Nr. Order-No. No. de Cde. Ref.-Nr.	Modell Type Modelo Modelo	Menge Quantity Nombres Cantidad	Bedienteile RS / SM	Operating parts	Eléments de function	Partes de manejo
1	50 74 529	RS / SM	1	Zündschloßhalter	ignition lock support	support antivol	soporte
2	79 00 296	RS / SM	1	Zündschloß	ignition lock	antivol	candado
3	00 31 518	RS / SM	2	Scheibe 16x22x1 DIN 988	washer	rondelle	arandela
4	6 91 959	RS / SM	1	Zündschlüssel	Key	Clé	Llave

Primo 550 / H / R / HR / RS / HRM

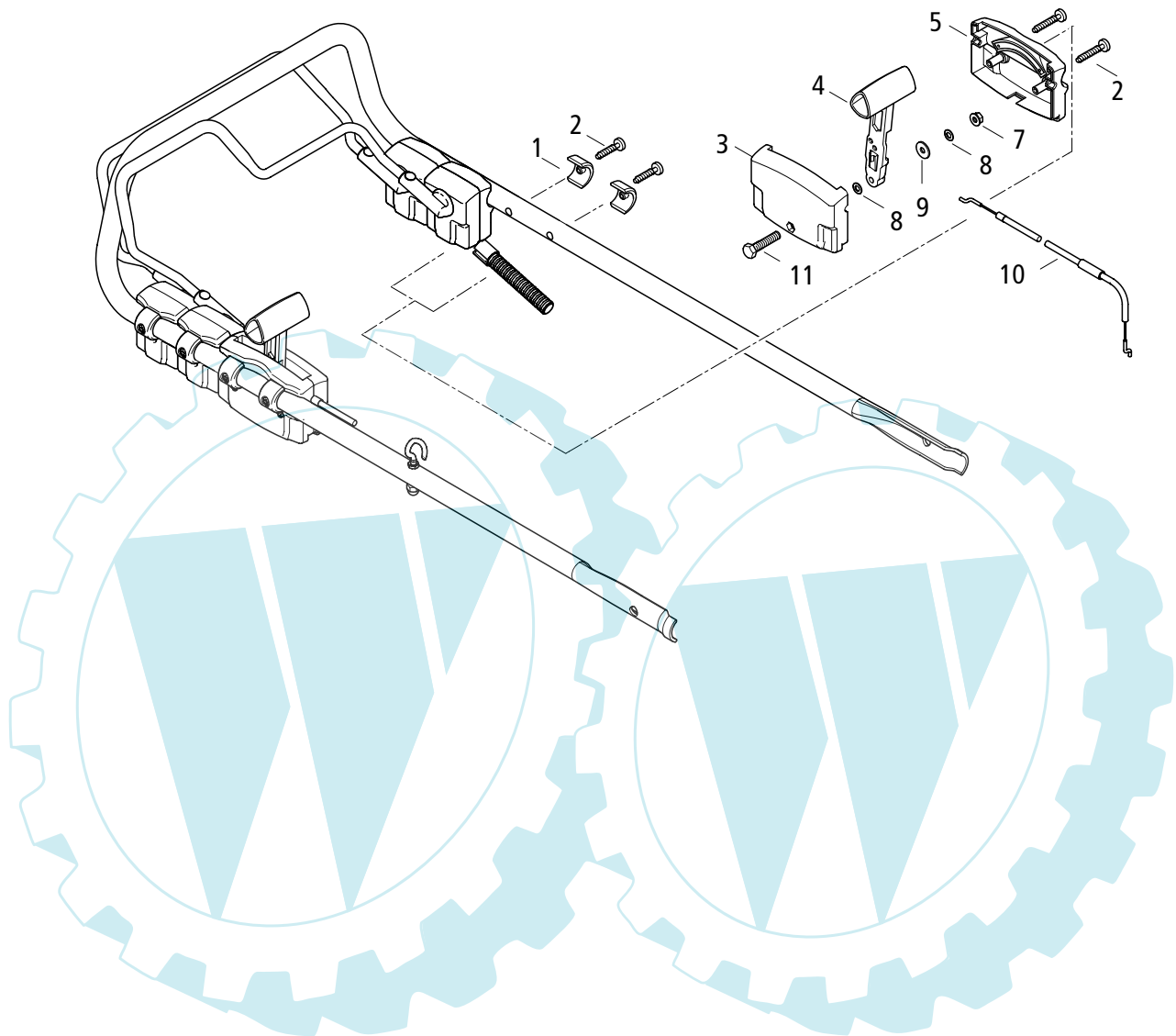
Bestell-Nr. Order-No. No. de Cde. Ref.-Nr.	Modell Type Modelo	Seite Page Page Pagina
00 10 544	1	7
00 10 583	1	6
00 11 310	1	6
00 12 125	1	11
00 12 171	1	9
00 12 184	1	3
00 12 279	1	3
00 12 375	2	7
00 17 103	1	5
00 17 110	2	8
00 17 113	2	8
00 18 183	1	3
00 18 185	2	3
00 18 185	2	4
00 18 185	4	5
00 18 185	8	6
00 18 185	4	6
00 18 193	4	4
00 18 193	2	5
00 18 193	4	6
00 18 257	8	2
00 18 258	4	2
00 18 276	8	3
00 18 282	2	3
00 18 283	3	7
00 18 305	3	7
00 18 336	4	2
00 18 344	1	5
00 18 346	1	2
00 18 358	5	9
00 18 358	4	10
00 18 358	4	11
00 18 376	2	9
00 18 376	2	7
00 18 402	1	3
00 20 116	1	9
00 20 122	1	6
00 20 122	1	9
00 24 110	1	9
00 24 121	4	2
00 28 107	1	5
00 28 111	1	2
00 28 116	1	3
00 28 116	1	3
00 28 119	1	11
00 30 100	1	6
00 30 108	4	2
00 30 125	1	2
00 30 125	2	3
00 30 125	1	11
00 30 164	2	8
00 31 210	2	4
00 31 210	2	5

Bestell-Nr. Order-No. No. de Cde. Ref.-Nr.	Modell Type Modelo	Seite Page Page Pagina
00 31 210	2	6
00 31 293	2	7
00 31 295	2	7
00 31 497	1	6
00 31 518	2	12
00 31 537	2	5
00 31 540	4	4
00 31 540	2	5
00 31 540	4	6
00 31 552	2	5
00 31 617	1	3
00 31 618	2	5
00 33 245 25	1	3
00 33 392	1	3
00 33 398	2	3
00 34 177	1	7
00 40 196	2	5
00 40 197	2	9
00 40 197	1	10
00 44 286	2	9
00 44 286	2	10
00 53 213	4	5
00 55 102	1	3
00 55 104	2	9
00 55 104	2	10
00 55 134	2	5
00 55 244	2	3
00 57 206	1	3
00 57 220	1	3
00 57 221	1	3
00 61 336	2	5
00 64 427	1	10
00 69 218	1	7
00 71 213	1	2
00 71 227	1	3
00 71 235	1	3
00 72 102	1	5
00 72 111	1	9
00 72 111	2	11
00 72 143	1	5
00 72 145	1	3
00 72 155	2	4
00 72 155	2	5
00 72 155	2	6
00 72 158	1	7
00 72 176	1	3
00 73 299	1	2
00 75 123	2	7
00 84 572	1	2
00 94 293	4	8
20 00 401	1	7
20 00 425	1	7
20 00 497	1	7
20 43 411	1	2

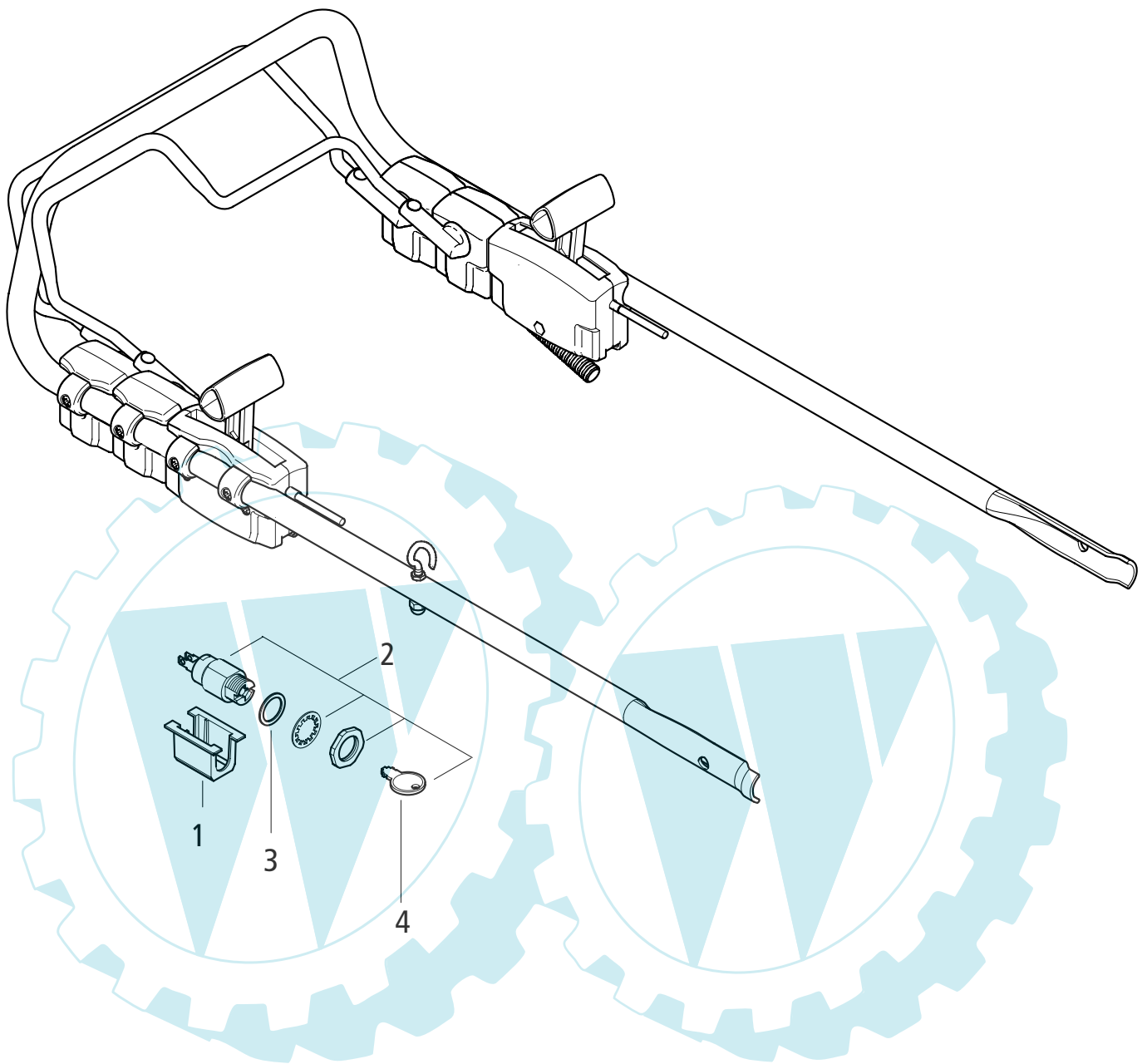
Bestell-Nr. Order-No. No. de Cde. Ref.-Nr.	Modell Type Modelo	Seite Page Page Pagina
30 00 227	1	5
38 00 351	1	9
38 00 353	1	9
38 00 355	1	9
38 00 358	1	9
38 00 360	1	11
38 00 361	1	10
50 11 714	1	3
50 11 715	1	3
50 16 100	1	10
50 31 223	1	7
50 31 980	1	9
50 35 111	1	9
50 35 112	1	10
50 35 965	1	8
50 36 362	1	3
50 36 403	1	2
50 36 406	1	9
50 38 437	1	5
50 38 438	1	5
50 42 818	2	2
50 42 824	2	4
50 42 824	4	5
50 42 824	2	6
50 42 828	1	7
50 42 830	1	6
50 42 860	1	3
50 43 356	1	6
50 43 961	1	7
50 43 995	1	7
50 45 702	2	5
50 48 372	1	3
50 73 577	1	7
50 73 618	1	2
50 73 631	2	5
50 73 645	1	2
50 73 670	1	2
50 73 670 27	1	2
50 73 673	1	7
50 74 100	1	8
50 74 102	2	4
50 74 104	2	6
50 74 110	4	9
50 74 110	2	10
50 74 110	2	11
50 74 122	1	9
50 74 124	2	5
50 74 125	2	5
50 74 126	1	9
50 74 127	1	9
50 74 127	1	10
50 74 130	1	5
50 74 131	1	5

Bestell-Nr. Order-No. No. de Cde. Ref.-Nr.	Modell Type Modelo	Seite Page Page Pagina
50 74 157	2	5
50 74 175	2	4
50 74 175	4	6
50 74 176	2	6
50 74 176	2	4
50 74 204	2	10
50 74 246	2	8
50 74 440	2	9
50 74 529	1	12
50 74 562	1	2
50 74 860	2	8
50 74 861	2	8
50 74 910	1	7
50 74 911	1	7
50 74 950	1	9
50 74 956	1	9
50 74 956	1	11
50 74 958	2	9
50 74 958	2	10
50 74 959	2	9
50 74 959	2	10
50 74 976	2	8
53 00 585	1	3
53 00 613	2	6
53 00 624	1	6
53 00 625	1	4
53 00 632	2	4
53 00 634	1	2
53 00 639	2	8
53 00 640	1	2
53 00 668	1	5
53 00 669	1	5
53 00 674	2	5
53 00 683	1	5
53 00 531	1	7
53 00 678	1	3
58 00 276	1	6
58 00 452	1	3
58 00 454	1	3
58 00 455	1	6
58 00 458	1	3
58 00 478	1	9
58 00 479	1	11
58 00 487	1	10
58 00 488	1	11
58 00 491	2	9
58 00 491	2	10
59 00 772	1	2
59 00 774	1	2
6 91 959	1	12
79 00 296	1	12
79 00 297	1	2

D

Allgemeine Richtlinien für die Bestellung von Original SOLO Ersatzteilen:

Voraussetzung für eine reibungslose Erledigung sind folgende Angaben:

1. Ersatzteil-Bestellnummer
2. Gewünschte Anzahl
3. Typenbezeichnung des Geräts

Diese Ersatzteilliste ist für die Lieferung und Ausstattung von SOLO Erzeugnissen unverbindlich.

Im Interesse der technischen Weiterentwicklung bleiben Konstruktionsänderungen vorbehalten.

GB

General Directions for Ordering Original SOLO Spare Parts:

For correct and diligent processing of your order, please give the following information:

1. Spare Part number
2. Quantity
3. Model and serial number
4. Shipping instructions

Delivery is made in accordance with our general sales and delivery conditions. This spare parts list is non-committal for us with regard to delivery and layout of SOLO products. In favour of technical improvements, design modifications are subject to change without notice.

F

Directives générales pour les commandes de pièces de rechange d'origine SOLO:

Il est indispensable de préciser dans toutes les commandes de pièces:

1. le numéro de référence de la pièce
2. la quantité
3. le type de la machine
4. le mode d'expédition

Les livraisons sont effectuées dans le cadre de nos conditions générales de vente. Toutes modifications réservées.

E

Directivas Generales de pedido de la firma SOLO:

Por adelantado de un arreglo sin dificultades necesitamos siguientes indicaciones:

1. Número de repuesto
2. Numero de cantidad
3. Modelo y número de serial
4. Instrucción de Envío

Esta lista de repuestos no es obligatoria para los envíos y/o forma de equipo de los productos SOLO. En el interés del constante desarrollo debemos reservarnos el derecho de cambios.